

PILOT HOLE

ALIGN PILOT AND SLOT IN ADAPTOR WITH GASKET IN BETWEEN, BOTH SIDES (ADAPTOR SHOULD BE INSTALLED AS SHOWN) SUPPLY 50-150 PSI TO 1/8" NPTF PILOT PORT IN ADAPTOR.

DO NOT ALIGN PILOTS IN BODY, END CAP AND SOLENOID

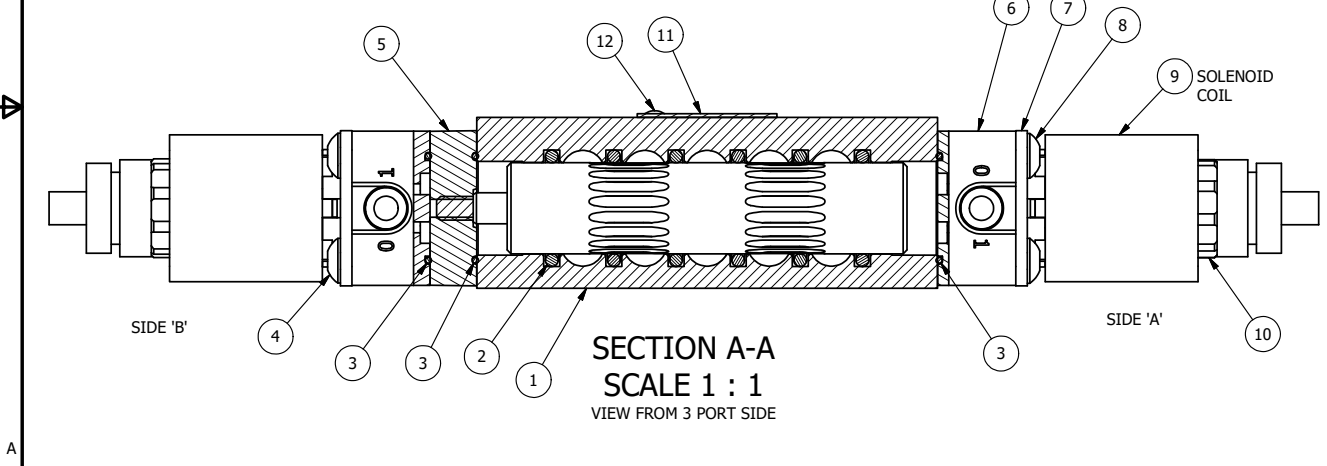

FLG	QTY	PART NO	DESCRIPTION
12	2	V-212	SCREW, #2 X 3/16 DRIVE, TYPE U, OVAL HEAD, STAINLESS STEEL
11	1	AN-114	NAMEPLATE, BLANK, FOR VALVES WITH SPRINGS OR DETENTS
10	2	V-556	NUT, SOLENOID, TOP EXHAUST, KNURLED
9	2	V-612-3	ATEX COIL 24 VDC WITH 3 METER CORD. NASS # 1215 30.1-001/6896.
8	4	V-584	SCREW, 10-24 X 1, BUTTON HEAD SOCKET CAP WITH MICROSPHERE APPLIED TO THREADS.
7	2	SEC3-7	PLATE, RE-INFORCEMENT, SOLENOID, STAMPED, 304 STAINLESS
6	2	V-550-1	SOL OPER, END MOUNT, NON-LOCKING O-RING
5	1	AY-EMY3G	ASSY - SPR CTR, OPEN CTR SPL, END MOUNT SOLENOID, 1/4" & 3/8" VALVES
4	4	V-601	SCREW, 10-24 X 1-1/2, BUTTON HEAD SOCKET CAP WITH MICROSPHERE ADHESIVE
3	3	EMG3	GASKET - END MOUNT SOLENOID, BUNA-N, 1/4" & 3/8" VALVES
2	6	V-39	O-RING, VITON, STD BODY, 1/4" & 3/8" VALVES
1	1	B2-1E	BODY - SOLID, BUTTON BLEEDER, ANODIZED, 1/4" SIDE PORT VALVE

NOTES:
1) ALWAYS GIVE VALVE MODEL AND PART NUMBER WHEN ORDERING PARTS.

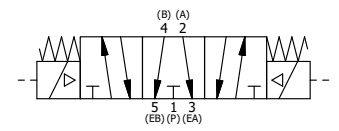

LIMITS ON DIMENSIONS UNLESS OTHERWISE SPECIFIED		2-PL DECIMAL ± .01 3-PL DECIMAL ± .005 FRACTIONAL ± 1/64 ANGULAR ± 1/2°		AAA PRODUCTS INTERNATIONAL 7114 Harry Hines Blvd Dallas, TX 75235
DRAWN: RMckenna	DATE: 6/11/2016	CHECKED: KWaite	DATE: 6/11/2016	
SCALE: 1 : 1	SHEET: 1 OF 1	RELEASED: HWomack	DATE: 6/11/2016	
TITLE: 1/4" SIDE PORT, DBL SOL, 3 POS, SPR CTR, SOL SHFT, FLOAT CTR SPL, ATEX, 24VDC, EXT PILOT			PART NO.: ESY2GTZ 24VDC	REV.: A

A	NO.	DATE	REVISION
	6/1/2018	ECG3 GASKET TO EMG3, CHNGD END CAP GEOM.	

THE INFORMATION CONTAINED WITHIN THIS DOCUMENT IS PROPRIETARY TO AAA PRODUCTS AND MAY NOT BE DISCLOSED WITHOUT PRIOR WRITTEN CONSENT

P:\Engineering\product\Valve Assembly\Standard\DWG\ESY2GTZ 24VDC.dwg